



Total Logistics Solution



영림목재(주)

NAMURO

| Table of Contents

1. Younglim Timber
2. Division & Partners
3. Products (Logistics)
4. Products (Buildings)

Younglim Timber

- 대표이사 : 이경호
- 1969년 설립 (52주년)
- 종업원수 : 50 (Korea) / 120 (China)
- 사업영역 : 가구, 플로어링(바닥재), 데크, 사이딩, 파렛트 등
- 자회사 : 장연(주)
Anhui Dongtai Metal (Nanjing)
China Younglim Trading (Beijing)
- 보유인증현황 :
 - 1) ISO 9001, 14001
 - 2) KS F 3103, 3126 (목질 플로어링보드)
 - 3) EPAL, CP 유럽 표준 파렛트 인증 (한국 유일)
 - 4) FSC-CoC 인증



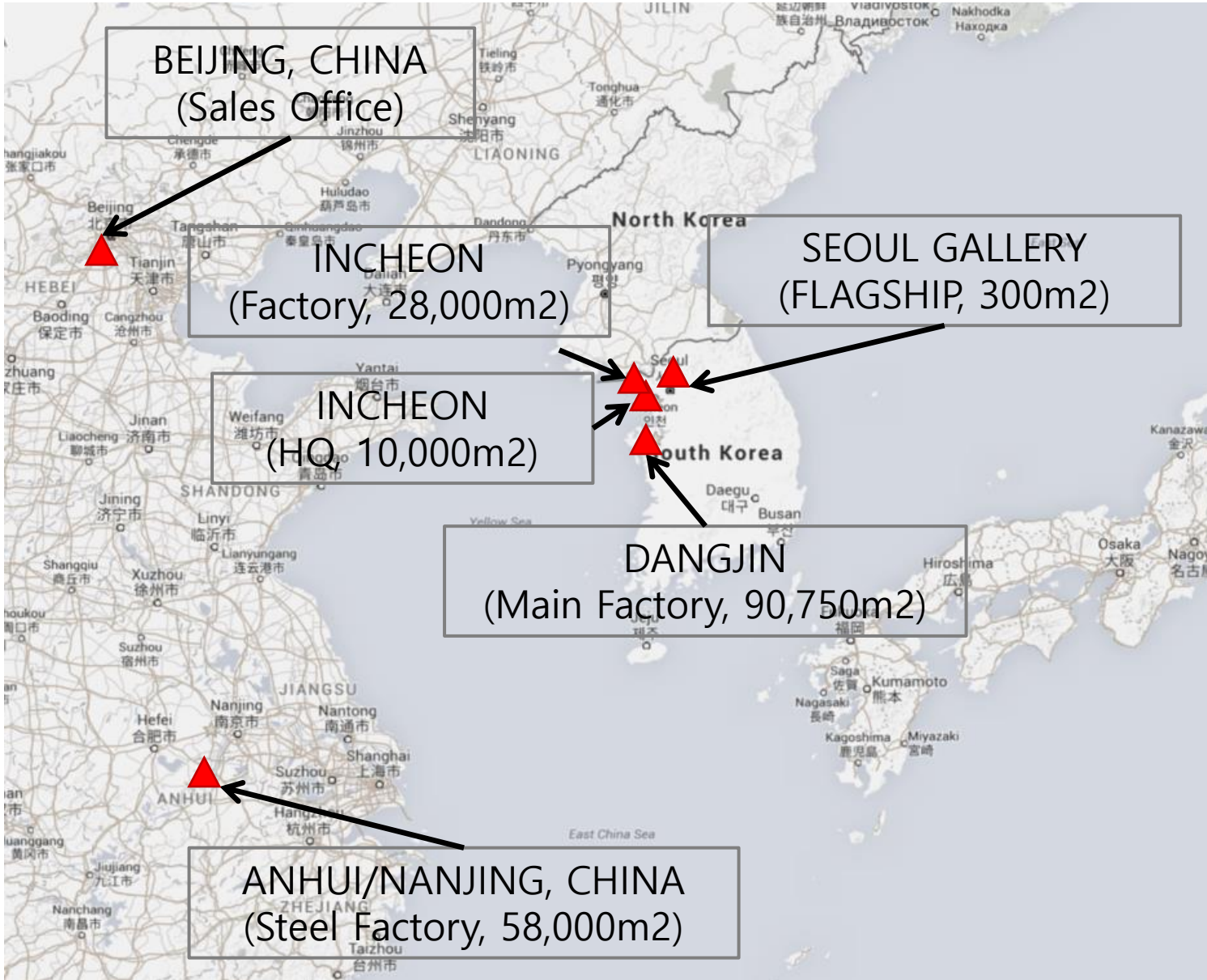

HQ (Incheon)



Incheon Gallery



Dangjin Factory : Total 6 factories / 7th is developing



Seoul Gallery

Younglim Timber

Anhui **Dongtai** Metal Packaging

Anhui Dongtai
Metal



Anhui Dongtai Metal

1. 한/중/일 합작회사
(2014년 9월 설립)

2. 철제 물류/포장 용기
제작

3. 매출 : 98억 /
직원 : 120명

4. 설비

1) 자동로봇용접기 : 7대

2) 자동 파이프 절단기

3) 자동 철판 절단기

4) 프레스 8대

5) 자동 세척기(酸처리)

6) 자동 분체도장 라인



Enterprising 진취성
YOUNGLIM TIMBER/JANG YEOUN
KOREA

Productivity 생산성
RIQIAN LOGISTICS EQUIPMENT
CHINA

Quality 품질
CS-JAPAN
JAPAN

Anhui Dongtai Metal

1. 新공장 이전 완료
2. 토지: 58,000 m²
3. 공장: 23,000 m²
(1차)
(2021년말까지 2차 건설
완료)
4. 용접로봇 5기 외
서비 추가

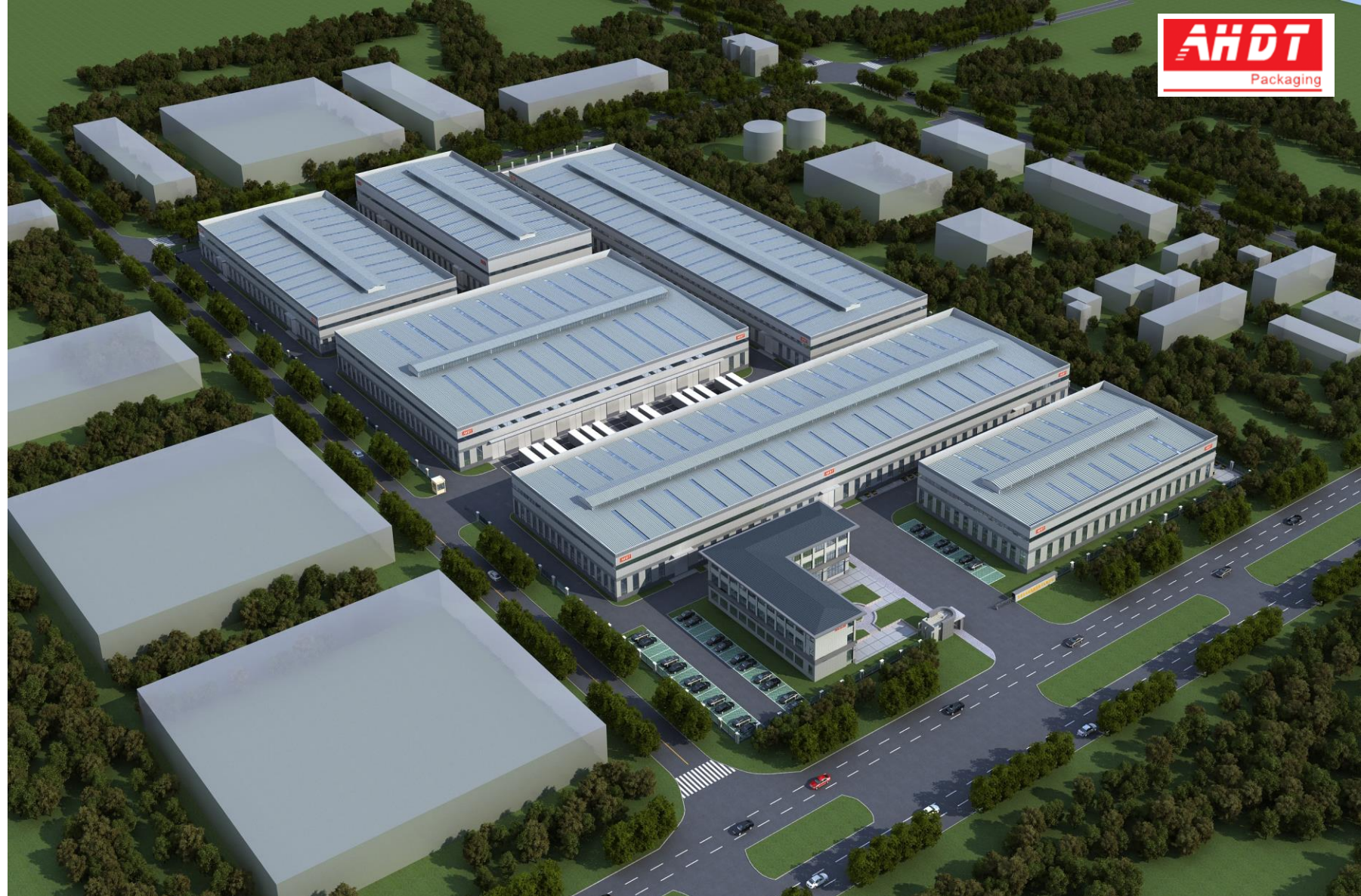



European Pallet Association e.V.



등록 화물적재용 랙

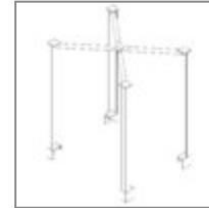

한국분류 : G1510
출원번호 : 3020130027444
등록번호 : 3007648740000
공개번호 :
출원인 : 영림목재(주)

등록 적재용 랙 보관대

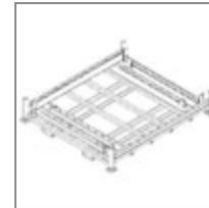

한국분류 : G15190
출원번호 : 3020130027450
등록번호 : 3007517140000
공개번호 :
출원인 : 영림목재(주)

등록 컨테이너

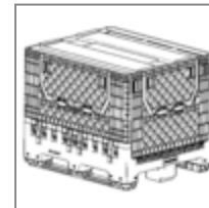

한국분류 : G1520
출원번호 : 3020080002931
등록번호 : 3004857230000
공개번호 :
출원인 : 영림목재(주)

물류 사업부

Total Logistics Solution

1. 사업 분야

- 전 제조공장
- 전 물류센터
- 전세계 공동 물류



2. 핵심 기술

- 목재, 철제, 플라스틱, 종이, 물류 등

다양한 솔루션 보유

- 중국의 한, 중, 일 합작공장 (안후이성)

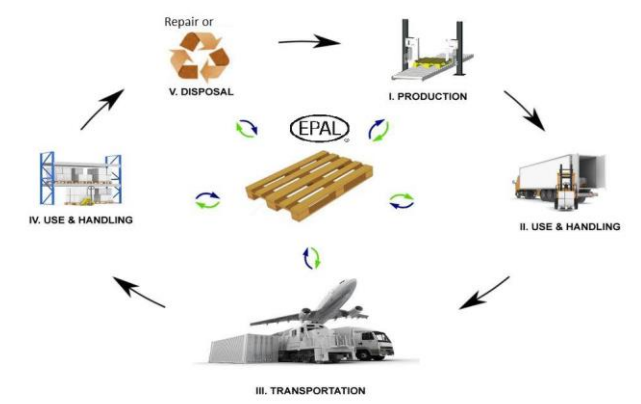
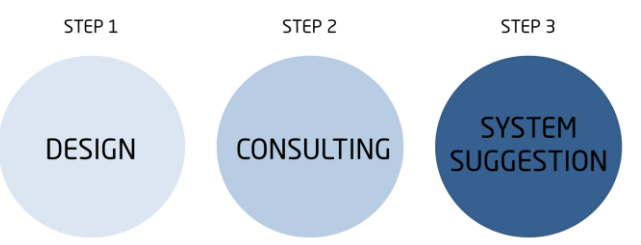

Products Matrix - LG Chemicals / Electronics

Rubber	Battery	Housys	System
<p>Pallet</p> <p>CP4 Pallet (대산)</p>	<p>Pallet</p> <p>EPAL 파렛트</p>	<p>Pallet</p> <p>EPAL 파렛트</p> <p>창호 운반 렉</p>	<p>Consulting</p> <p>Open Pooling</p> 
<p>Box</p> <p>Good pack</p> <p>IPC box</p>	<p>Box</p> <p>르노 칸구 렉</p> <p>배터리 포장</p> <p>전해질 포장</p>	<p>Flooring</p> <p>원목 마루 (제안)</p> <p>기능성 마루 (개발)</p>	<p>Design Consulting</p> 
<p>Packaging</p> <p>IFC : 기능성 톤백</p>	<p>모터 포장</p>	<p>Window</p> <p>원목창호(아코야)</p>	

Products Line

Logistics

WOOD

목재



-
- Epal Pallet
 - CP Pallet
 - LVL Pallet
 - Skid Pallet
 - Wooden Pallet
 - Wooden Box
 - Wooden Rack
 - Folding Plywood Box
 - Wooden Collar

STEEL

스틸



-
- Steel Pallet
 - Steel Stacking Pallet
 - Cross Support
 - IBC Steel Container
 - Iron Packaging Container
 - Mesh Container
 - Rack For Auto Motor Gear
 - Roll Container
 - Storage Rack/Intainer
 - Wire Container
 - Wire Basket
 - Wire Decking

PLASTIC

플라스틱



-
- Plastic Pallet
 - Plastic Box
 - Danpla Box
 - Bulk Container
 - Sleeve Box

ETC

기타



-
- Eco Liquid
 - Paper IBC For Bulk Liquid
 - Recodi Box
 - Re-Birth System

Products Line

Pallet

EPAL Pallet

- 유럽형 리터너블 시스템
- 목재 파렛트
- 품질
- 재판매/재사용 가능

유럽형 규격(800x1200mm 외)

친환경, 보수의 편리성

인증된 자재만을 사용. 외부 전문 검사기관

파렛트의 재사용, 재판매가 가능 / **원가절감**

What's the reason to choose EPAL?



Why EPAL?

EURO-pallets bearing the EPAL quality mark, certifying they have been inspected by EPAL, offers global safety.

Only quality inspected EURO-pallets guarantee smooth material flow – anywhere. Either within your business or internationally – in transport and storage.

These are the real benefits of EPAL.

BENEFITS

- 1. Safer transport**
your goods arrive safely
- 2. Stable storage**
stable storage of your goods is guaranteed
- 3. Optimum operational safety**
you work in a safer environment

Safety

Cost Down

EPAL Pallet



구분	EPAL1	EPAL2	EPAL3
규격	800X1200X144	1200X1000X162	1000X1200X144
특징	표준형(약 95%이상)	컨베이어 타입	12형(한국, 중국 호환)

EPAL Pallet



▶ 그 외 일본, 대만, 인도, 태국 등에 수출

CP Pallet (Chemical Pallet)

- 유럽형 표준 파렛트
- 목재 파렛트
- 품질
- 재판매/재사용 가능

화학제품 표준 파렛트, CP 1 ~ 9, 총 9가지 유럽 표준 규격

친환경, 보수의 편리성

자체 품질 관리, EPAL CP 파렛트 검토 중

파렛트의 재사용, 재판매가 가능 / **원가절감**







Plastics Pallet

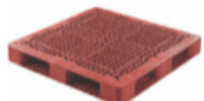
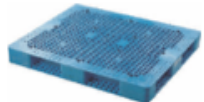

- 파렛트 유통
- 금형 보유
- 금형 설계/투자

OEM/다양한 공급처 보유

렌탈용 11형, 12형 파렛트 금형 보유 (영림 투자)

신규 파렛트 개발, 금형 투자 가능

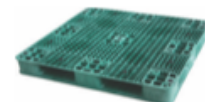
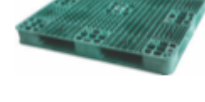
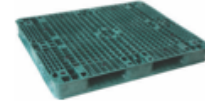
Name	Form	Dimensions (mm)	Weight (kg)	Dynamic Load	Static Load
 N11	Double-side 4-way	1,100×1,100×150	19.5		
 N12	Double-side 4-way	1200×1000×150	24.0		
 PP-A-1	Single-side	1,100×1,100×120	5.8	1 ton	2 ton
 PP-A-2	Single-side	1,100×1,100×120	7.6	1 ton	2 ton
 PP-A-3	Double-side	1,100×1,100×120	11.3	1 ton	4 ton
 PP-B-1	Single-side	1,100×1,100×130	9.5	1 ton	4 ton

Name	Form	Dimensions (mm)	Weight (kg)	Dynamic Load	Static Load
 PP-C-1	Single-side	1,100×1,100×150	10.2	1 ton	4 ton
 PP-D-1	Single-side	1,200×1,000×120	7.0	1 ton	2 ton
 PP-D-2	Single-side	1,200×1,000×120	12.0	1 ton	4 ton
 PP-E-1	Single-side	1,200×1,000×150	20.0	1 ton	4 ton
 PP-F-1	Single-side	1,300×1,100×120	10.2	1 ton	4 ton
		1,300×1,100×120	13.5	1 ton	4 ton

Products Line

IPC Box (Rubber Box)

IPC Steel Box

인조 고무 적재용 박스



- » 외형 처리: 도장/전기 아연 도금 및 높은 방부성
- » 그린(환경) 제품, 국제적 환경 보호 추세 준수
- » 창고 보관이나 운반 니즈를 크게 만족시키는 접이식 디자인, 공간을 효율적으로 활용하고 운송 비용을 절감
- » 사용 용이, 도구적 도움 없이 한 사람이 조립과 폐기 가능
- » 작은 컨테이너이며, 일반적으로 합성 고무와 다른 제품들에 폭넓게 적용되고, 화학 공업, 농업 그리고 그 외 다양한 산업에 사용



IPC Steel Box

인조 고무 적재용 박스

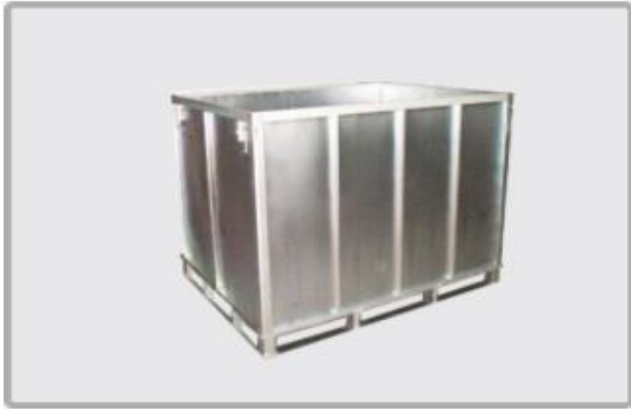

Zinc-Galvanized Iron Packaging
Container



Powder Coating Iron Packaging
Container



Zinc-Tube Iron Package container



Hot-Galvanized Iron Package
container for Rubber



Hot Galvanizing Packaging Container

IPC Steel Box 납품실적

LOTTE | UBE
SYNTHETIC RUBBER



IPC Steel Box

Reusable

durable box designed for efficiency

All steel construction ensures product

Integrity

4-way entry pallet base for superior handling

Efficiencies

Suitable for both containerised and break-bulk

Shipping

Smart Solutions,
Versatile Applications



Easy

setup and knock down

Stack up to 11 or 13

high without need for a racking system

Designed to

Maximise

the packing density in 20' and 40' ISO sea containers

IPC Steel Box

합성고무

[제품자료\(MSDS 등\) ↓](#)

높은 탄성과 강성을 가진 합성 고분자 소재

합성고무란 높은 탄성과 강성을 가진 합성 고분자 소재로서, 내마모성, 반발탄성, 기계적 특성이 우수하여 주로 타이어, 벨트, 호스, 신발등에 사용되는 고기능성 소재를 말합니다.

Tag • 부타디엔 고무 부타디엔 반발 탄성

렌탈/회수박스 사용

일회용

BR

SBR

SSBR

NBR

BR(Butadiene Rubber)은 부타디엔을 용액 중합법으로 제조한 합성고무 제품으로, cis 함량이 높은 특징을 가지고 있습니다.

BR은 내마모성, 내굴곡성, 반발탄성, 내한성이 우수하여 주로 타이어, 신발, 골프공 등에 사용되고 있습니다.

Products Line

Steel Box (Battery, Motor...)

Steel Box - Design



메쉬컨테이너



와이어메쉬

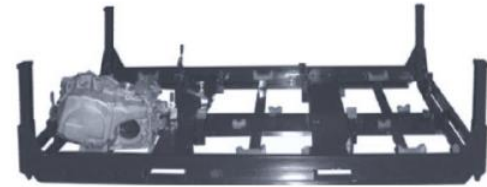

오더메이드 대차



X(크로스) 컨테이너



와이어 바스켓



롤테이너

Steel Box - Design



HOW TO FOLD



HOW TO SEPARATE

- » 개별구매 가능
- » 단가절감

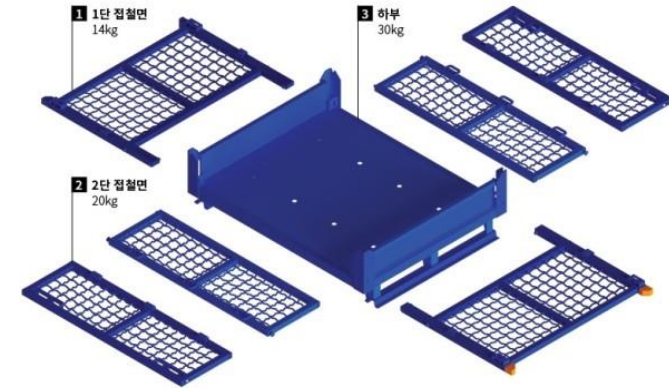

5 POINTS



- » 타 메쉬컨테이너와 다르게 손잡이가 안쪽으로 위치하여 파손율을 줄임
- » 모든 부분을 분리할 수 있어 파손시 파손 부품만 소량 구매를 통해 복구 가능
- » 발을 사용하여 기존 제품들과 호환
- » 대비되는 색상의 사용으로 원활한 작업 유도

DIMENSION

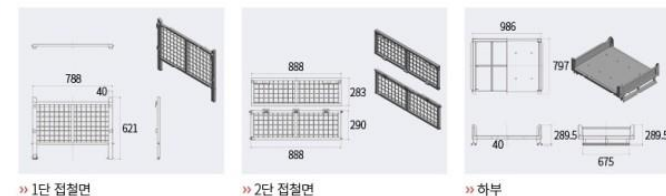

» 1단 집철면

» 2단 집철면

» 하부

Steel Box - Design

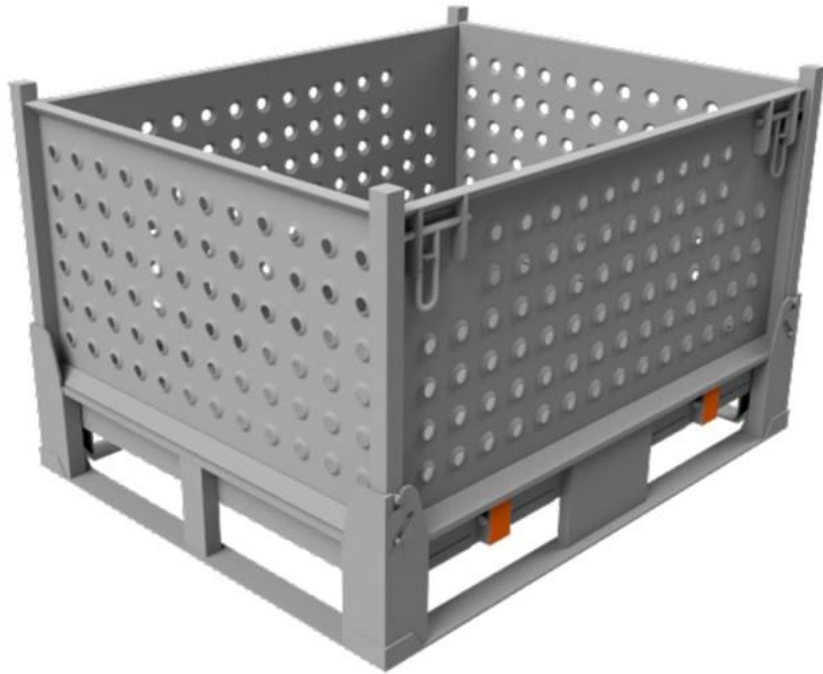

Steel Box - Design



Steel Box - Design

배터리팩 포장(광주기차) 제안

[A면] : 자리 및 사이즈 要

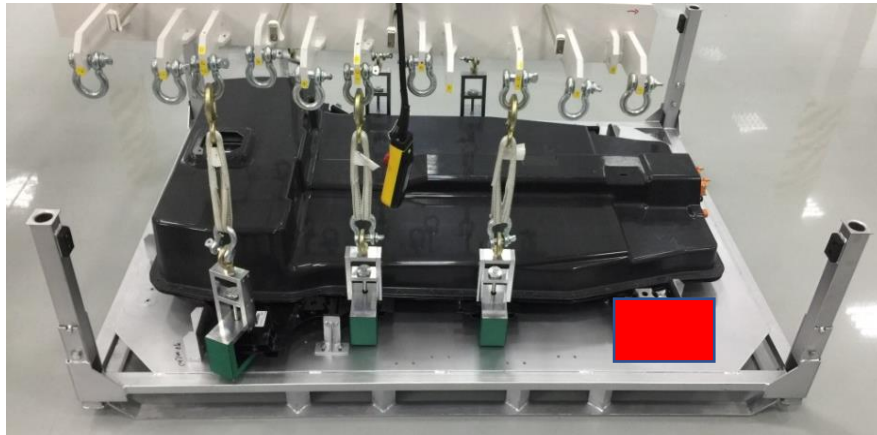

명판 위치(예정)

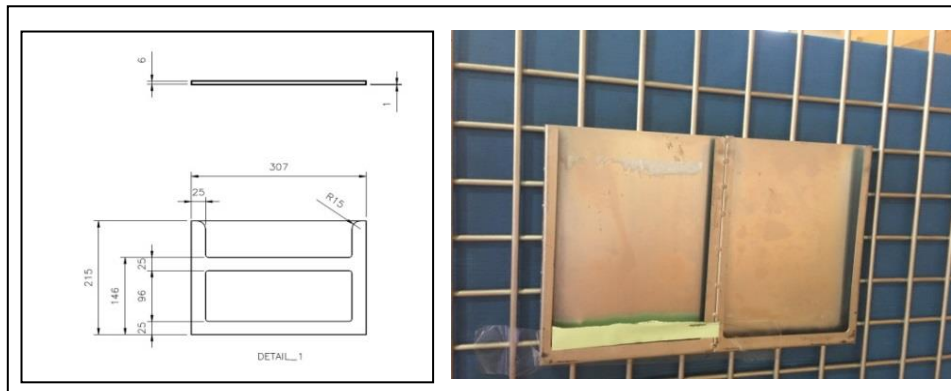

列4)



列1)



列2)



列3)

Steel Box - Design

PGM모터(동풍기차 - 납품 완료)

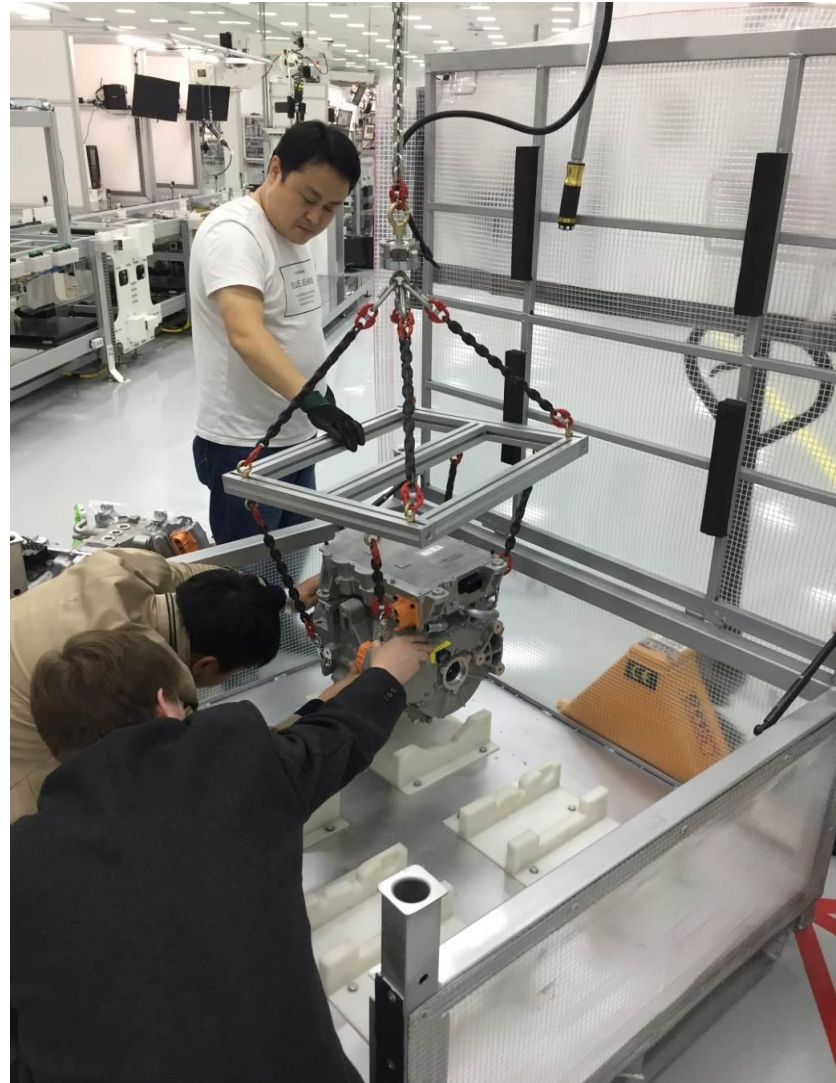

Steel Box - Design

한국-폴란드 리터너블 파렛트
(견적
진행)

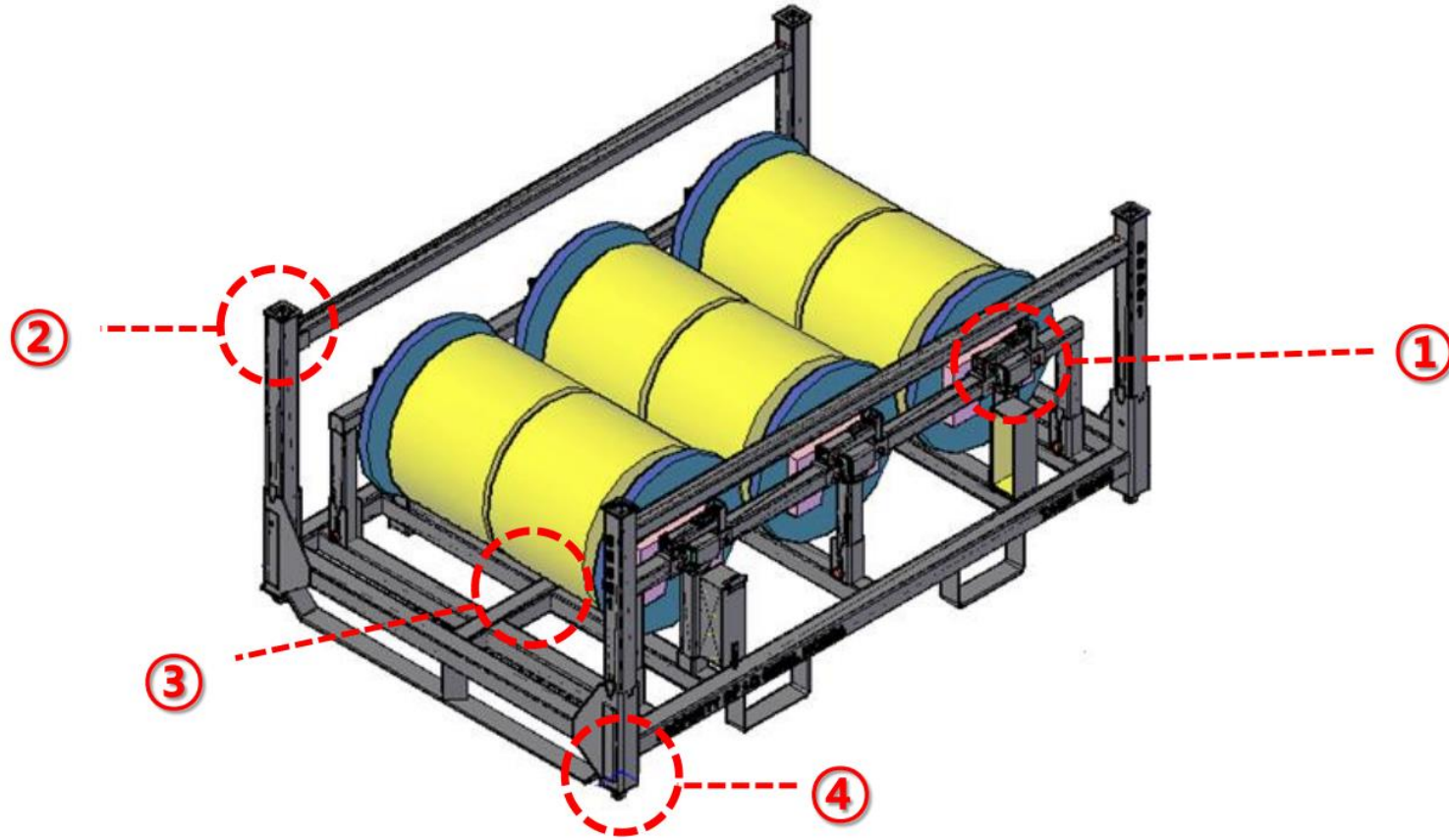

Steel Box - Design

르노
칸구렉

(견적 진행 중 고객요청으로 중단)

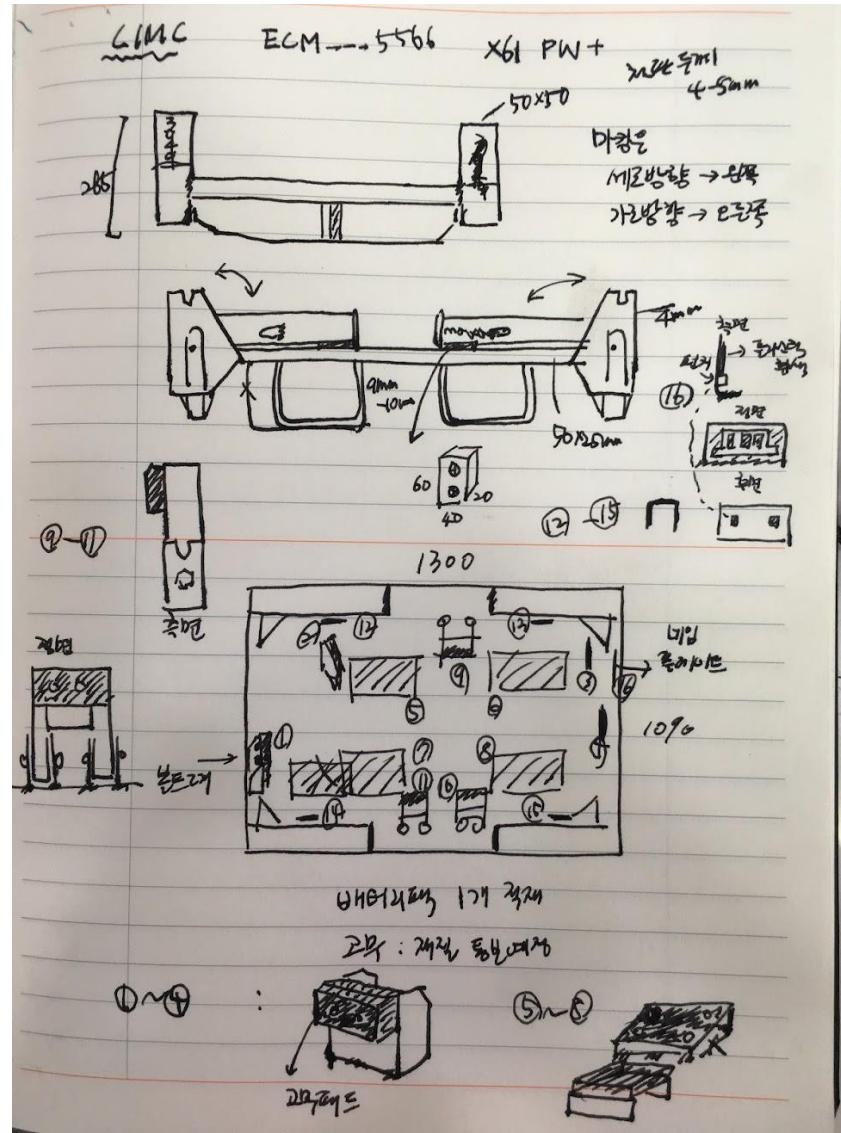

Steel Box Series



Products Line

Rolltainer series



롤테이너는 마트나 유통업체에서 많이 사용하는 박스형 대차로서, 무거운 중량물이나 한번에 싣기 힘든 소포장된 박스들을 손쉽게 옮길 수 있게 만든 대차입니다. 저희 롤테이너는 약 6년간 철제제품을 제작 및 판매해온 중국의 합작법인에서 생산되어 기술력과 품질을 보증할 수 있습니다. 또한, 용융아연도금제품도 가능하여 냉동창고에서도 사용할 수 있습니다.

Rolltainer is the Box type of Cart widely used in the supermarket/retail or logistics industries. You can easily move small boxes and Heavy products in this box. **Our Rolltainer is made from our Metal Factory making steel logistics products over than 6 years with high technology and quality which is proven.** We can also produce the galvanized one using in frozen warehouse.

▶ 롤테이너 실제사용



롤테이너 입출고





과자업체



자동창고용 롤테이너

롤테이너



선반형



일반형





Thanks for listening